

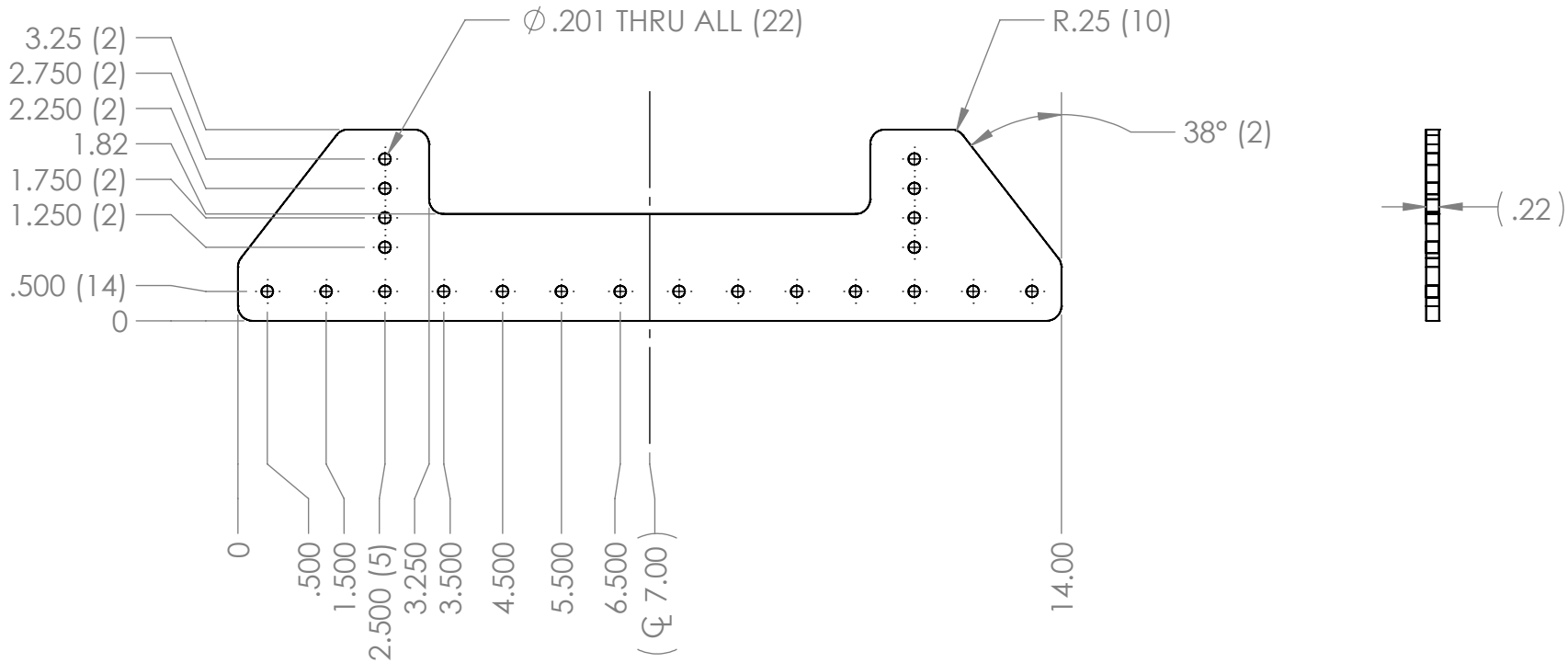

REVISION HISTORY			
REV.	DESCRIPTION	DATE	DRAWN BY
1	ORIGINAL PRINT	1/23/2026	P. YEUNG
2	REVISED HEIGHT GEOMETRY	2/2/2026	P. YEUNG

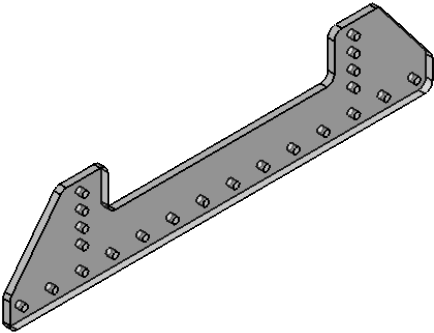

*** SEE CAD FOR ADDITIONAL TOOLPATH INFO***



UNLESS OTHERWISE SPECIFIED:		COMMENTS:				
DIMENSIONS ARE IN INCHES		DUAL DIMENSIONS ARE IN MILLIMETERS.				
TOLERANCES:		BREAK ALL SHARP EDGES.		TITLE:		
FRACTIONAL	±1/16			EVERYBOT 2026		
ANGULAR: MACH	±1°			TOP PLATE		
ANGULAR: BEND	±5°					
ONE PLACE DECIMAL	±0.1					
TWO PLACE DECIMAL	±0.01					
THREE PLACE DECIMAL	±0.005					
FOUR PLACE DECIMAL	±0.0005					
MATERIAL	CLEAR PC m-0031a	CHECKED	NAME	DATE	SIZE	DWG. NO.
FINISH	DEBURRED	ENG APPR.	NM	2/2/26	A	am-5804_top
DO NOT SCALE DRAWING		MFG APPR.			SCALE: 1:3	
		Q.A.			SHEET 1 OF 1	